

BODAS Pressure sensor PR4



- ▶ Thin-film measurement principle
- ▶ Measuring ranges 0 ... 50 bar, 0 ... 100 bar, 0 ... 280 bar, 0 ... 400 bar, 0 ... 420 bar, 0 ... 600 bar
- ▶ Output signal 0.5 ... 4.5 V ratiometric at supply voltage 5 V or SENT according to SAE J2716 JAN 2010
- ▶ Protection class IP67 / IP69K

Features

- ▶ Tightening torque up to 50 Nm
- ▶ High shock and vibration resistance
- ▶ High resistance to pressure peaks
- ▶ Very good temperature shock resistance
- ▶ High accuracy over the complete measuring range
- ▶ Compact robust construction
- ▶ CE conformity

Contents

Product description	2
Type codes	17
Technical data	19
Electrical connection	21
Dimensions	22
Mounting	23
Information	25
Accessories	29
Safety Instructions	30

Product description

This sensor is used for measuring pressure in hydraulic circuits. Due to its outstanding characteristics, it is also ideally suited for use in mobile hydraulics:

Shock and vibration resistance, type of protection, resistance to pressure spikes, resistance to temperature shock, EMC characteristics better than 150 V/m.

A resistance bridge is applied on a steel membrane using thin-film technology. The measurement principle uses a hermetically welded thin-film measurement cell, which ensures long-term leak resistance. The sensor signal can be directly evaluated by a BODAS controller RC.

Wiring of the sensor: PR4 xxx xx 05 /10

Recommended wiring of the sensor

The sensor is to be connected to the ECU according to the following wiring diagram and provided with a supply voltage of 5 V.

Sensor wiring in the ECU

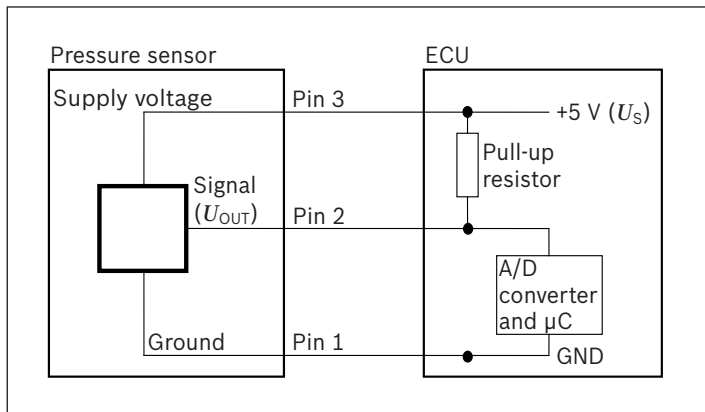

The allocation of the pins of the high-pressure sensor can be found in the chapter "Pin assignment".

The pressure sensor either delivers an analog output signal, which has a radiometric relation to the supply voltage, or a digital output signal.

Specification recommendation:

In the signal path of the control unit, a pull-up resistor of $4.64 \text{ k}\Omega \pm 5\%$ against U_s as well as a low-pass filter with a time constant of max. 0.7 ms should be provided.

The electric output of the sensor is designed in such a way that any malfunction due to cable breaks or short-circuits in the displayed wiring can be detected.

Other circuitries are possible, the diagnosis function may, however, be limited.

Resistor information

Designation		Value		
		Minimum	Typical	Maximum
Pull-up resistor to U_s	$R_{\text{Pull-up}}$	4.41 k Ω	4.64 k Ω	4.87 k Ω

Wiring of sensor PR4 xxx xx SE /10

The sensor is to be switched by the control unit according to the SENT specification SAE J2716 JAN 2010 and supplied with a supply voltage of 5 V.

The assignment of the connector pins of the high-pressure sensor deviates from the SENT standard as described in chapter "Pin Assignment".

Characteristics of the sensor PR4 xxx xx 05 /10

Output voltage as function of the pressure

The signal output voltage is (up to the nominal pressure) calculated from the actual pressure as follows:

$$U_{OUT} = (c_1 \times p + c_0) \times U_S$$

Key

- U_{OUT} Signal output voltage
- U_S Supply voltage (typical 5 V)
- p Pressure [MPa]
- c_0 = 0.1
- c_1 = $0.8 / p_n$
- p_n Nominal pressure [MPa]

Signal output voltage U_{OUT}

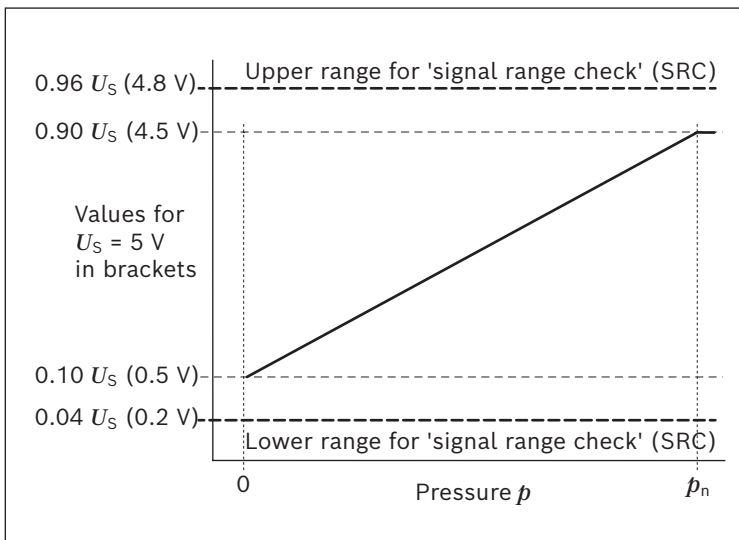

Behavior after reset and initialization for the sensor PR4 xxx xx 05 /10

In case of certain errors, a reset is triggered in the sensor. These are then generated every 400 ms. After a reset, and during the subsequent initialization of the sensor, the output is pulled to ground. If the error is still present, the output signal remains in the lower error band. In case,

the error is no longer present, the output signal controls its value into the applicable operating range. The course of the output signal and the related typical time at room temperature, after the reset, are shown in diagram below.

Representation of the time after reset and initialization

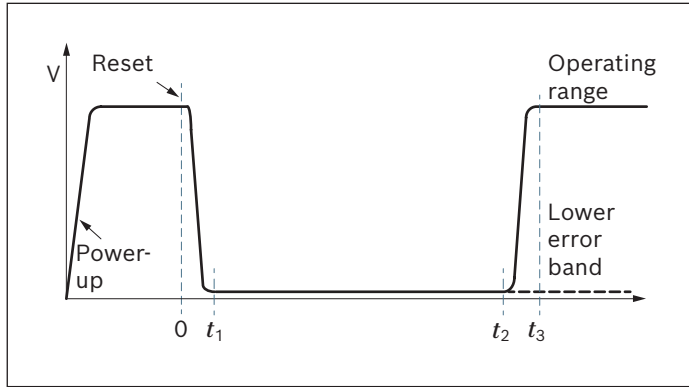

Typical [ms]	t_1	t_2	t_3
CRC OK	0.03	0.9	1.1
CRC NOK	0.03	2.1	2.3

Behavior after undervoltage and overvoltage PR4 xxx xx 05 /10

In case of undervoltage or overvoltage detection, the output is drawn to ground.

Error diagnosis for the sensor PR4 xxx xx 05 /10

Since the sensor characteristic of the upper operating range is limited, overpressure conditions can be distinguished from errors.

- 0 = no error band and no reset
- 1 = lower error band and no reset
- 2 = lower error band and reset is triggered

The coding of the response to an error in the following table "Response of the sensor in case of error" is as follows:

Response of the sensor in case of error

Error description	Debounce characteristics	Error mode
Initialization, p (pressure) and T (temperature) not yet available		-1
Indicates that OTP Bit for final programming at Bosch of OTP Master is not set (lock-bit not set)	Error is set immediately, No reset is triggered	-1
1) Power-on Complete RAM check (Read/Write) Beginning of continuous ROM check		
2) Normal operation Continuous ROM check Continuous RAM check RAM/ROM checks DSP by Parity during each Access HW-Check of Signal Processor (Question/Answer) Signature monitoring of program counter	Error is set immediately, Reset is triggered	-2
1) OTP CRC check of boot loading failed 4 times (consecutive)	1) Error is set immediately, Reset is triggered	-2
2) Sum-check on trim data. Test carried out during boot loading and continuous normal cycle	2) Error is set immediately, Reset is triggered	
Test on Acquisition Chain Pressure by injection of test signal before ADC on power-up Thresholds are defined during EoL programming at Bosch for each sensor individually.	Error is set immediately, Reset is triggered	-2
Decimation interval error (Only possible in case of severe hardware malfunction)	No reset, debouncing next frame	-1
Pressure Sensor element failure (Wiring Detection)		
1) Power-On Common Mode at Power-On	1) Error is set immediately, Reset is triggered	-2
2) Normal operation Common Mode Current Modulation	2) Reset, debouncing next frame	
Signal input ADC too high, also for Sensor Element Error	No reset, debouncing next frame	-1
Signal input ADC too low, also for Sensor Element Error	No reset, debouncing next frame	-1
Reference temperature input too high or low	No reset	-1
Failure of internal temperature sensor --> HW Defects of ADC or PTAT itself	No reset	-1
Supply voltage too low Below the programmed threshold	No reset, debouncing next frame	-1
Supply voltage too high Above the programmed threshold	No reset, debouncing next frame	-1

Sensor characteristics PR4 xxx xx SE /10 and SENT protocol description

SENT configuration for PR4 sensor

The PR4 xxx xx SE / 10 output setting, according the SAE J2716 JAN 2010 standard is: *p/T*.

With the data nibbles 1-3 the SENT signal transmits a 12-bit data value "Fast-Channel 1" (pressure).

With the data nibbles 4-6 the SENT signal transmits a 12-bit data value "Fast-Channel 2" (temperature).

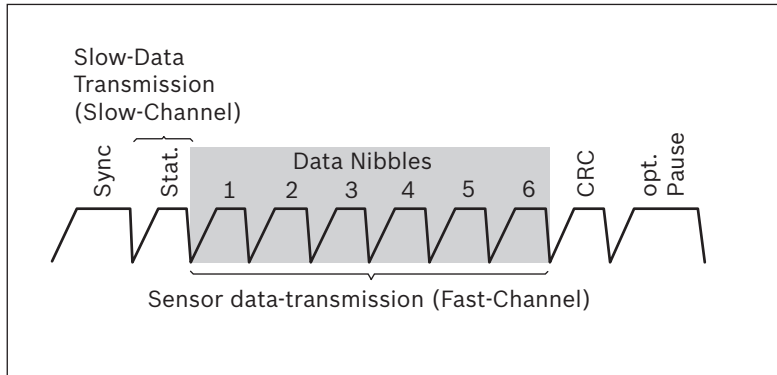

Serial communication / Slow-Channel / Slow-Data

PR4 uses the "Enhanced Serial Message" format with 8-bit MsgID and 12-bit Data (config bit C=0).

In order to compose serial messages in enhanced format,

two bit of each SENT message are being used. 18 consecutive error-free SENT messages are required to compose one serial message.

Set-up of the extended serial message from 18 sent messages

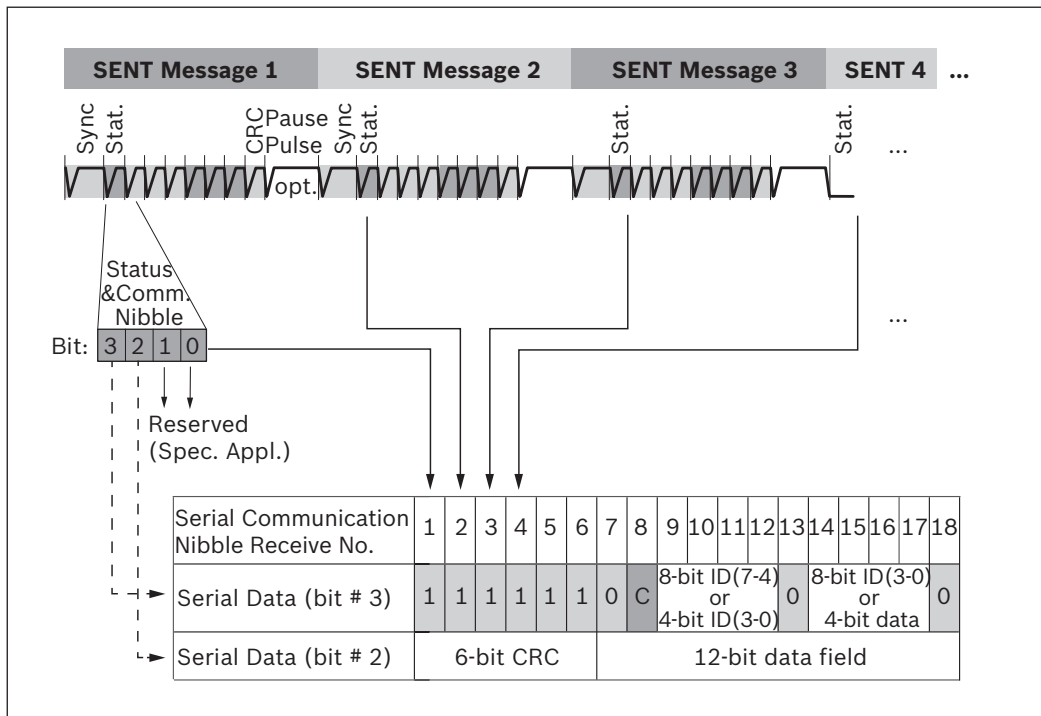

In the "slow-channel / slow-data", characteristic sensor data like coefficients, parameters, error information messages, OEM data, and so on are transmitted.

The sensor is delivered with the following settings:

("Configuration Shorthand" according to SAE J2716 JAN 2010)

	050 PR4 xxx xx SE /10	280 PR4 xxx xx SE /10	420 PR4 xxx xx SE /10	600 PR4 xxx xx SE /10
Pressure offset (P2)/ Nominal pressure (P3) ¹⁾	0 bar in the mode relative pressure/050 bar	0 bar in the mode relative pressure/280 bar	0 bar in the mode relative pressure/420 bar	0 bar in the mode relative pressure/600 bar
Maximal pressure for er- ror - flag	62.5 bar±5%	350 bar±5%	525 bar±5%	750bar±5%
Sensor type	<i>p/T</i>			
Tick length	3 µs			
Bandwidth	Minimum: 470 Hz Nominal: 523 Hz Maximum: 575 Hz			
Latency	Minimum: 1.13 ms Nominal: 1.25 ms Maximum: 1.4 ms			
Variable frame length	No			
Maximal temperature for error - flag	160 °C typically ±20 Kelvin (full functionality only guaranteed up to 140 °C)			
Number of data nibbles	6			
Pause pulse	Yes ("constant frame length")			
Serial protocol	"Enhanced Serial Protocol" with 8 bit ID and 12 bit data			
Fast-Channel 1	Pressure 12 bit			
Fast-Channel 2	Temperature 12 bit			
Length of one Fast-Data Message	0.846 ms±10%			
Length of one Slow-Data Message (18 Fast-Data Messages)	15.2 ms±10%			
8 Slow-Data Messages (Diag)	121.6 ms±10%			
All 32 Slow-Data Messa- ges	486.4 ms±10%			

¹⁾ The specific calculation rule for the nominal pressure P3 results from the 12-bit value X2 from the Slow-Channel data as follows:
 The least significant 3 bits as power of ten, the higher-order (9) bits as the mantissa.
 Example for X2 = 0x156: The nominal pressure corresponds to 42e6 [Pa] = 420 bar.

Transfer function of the signals of the sensor PR4 xxx xx SE /10
Transfer function pressure measurement signal

The measured pressure is transmitted as a digital value according to the SENT specification SAE J2716 JAN 2010 according to the following function in Fast-Channel 1 (measured values are contained in the Fast-Channel).

Measured pressure

$$p_{\text{ist}} = \frac{p_{\text{OUT,code}} - c_0}{k}$$

Transfer function pressure

$$p_{\text{OUT,code}} = k \times p + c_0$$

Key

- $p_{\text{OUT,code}}$ Digital 12 bit data value
 p Pressure [kPa] (Hinweis: 1 kPa = 0.01 bar)

The coefficients and other values are transmitted in the Slow-Channel, refer to the see "SENT-Slow-Channel Messages Order, meaning and values" chapter.

$$k = \frac{(Y2 - Y1)}{(X2 - X1)} = \frac{(C3 - C2)}{(P3 - P2)}$$

$$c_0 = Y1 - \frac{(Y2 - Y1)}{(X2 - X1)} \times X1 = C2 - \frac{(C3 - C2)}{(P3 - P2)} \times P2 = C2$$

Key

- k Slope
- c₀ Offset

Transfer characteristic for the pressure as 12-bit data values

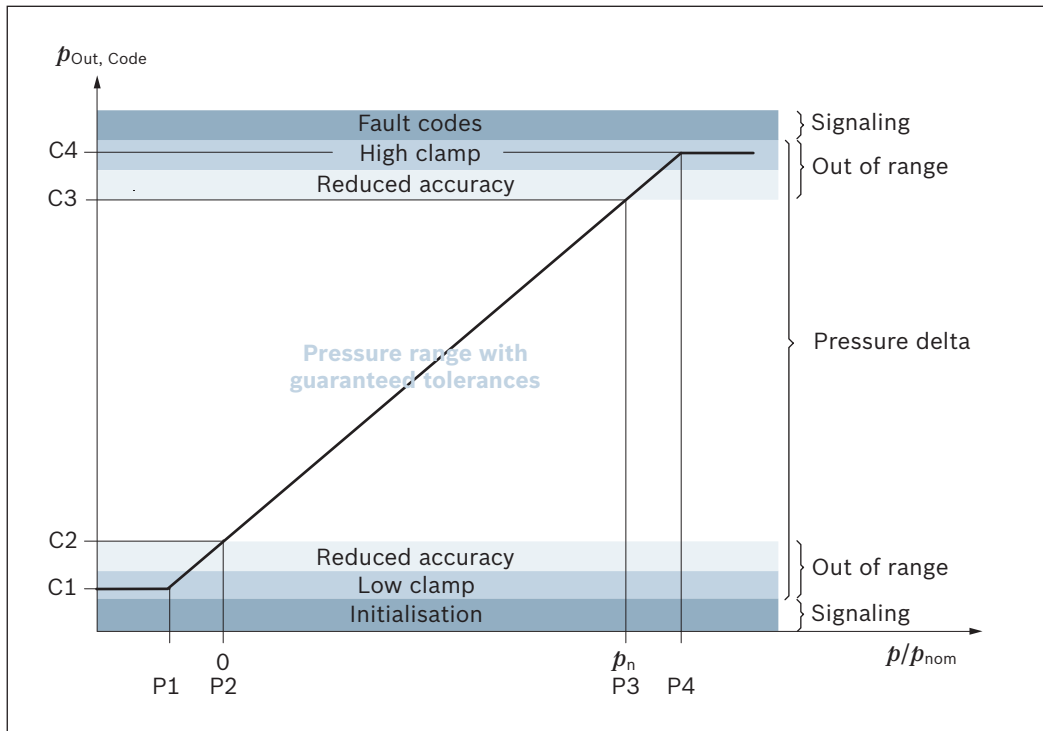

The assignment of digital value to pressure is shown in table "Characteristic parameters pressure", the accuracy of the sensor is defined in the section Tolerances

ances on temperature, pressure and life of the sensor PR4 xxx xx SE /10.

Characteristic parameters pressure

Parameter	050 0261.547.023 HPS5 50 bar	280 0261.547.010 HPS5 280 bar	420 0261.547.021 HPS5 420 bar	600 0261.547.015 HPS5 600 bar
P1	-259249 Pa	-1451796 Pa	-2177694 Pa	-3110991 Pa
P2 (X1)	0 Pa (0x0)	0 Pa (0x0)	0 Pa (0x0)	0 Pa (0x0)
P3 (X2)	5000000 Pa (0x195)	28000000 Pa (0xE6)	42000000 Pa (0x156)	60000000 Pa (0x1E6)
P4	5259249 Pa	29451796 Pa	44177694 Pa	63110991 Pa
C1 (Low clamp)	1 LSB	1 LSB	1 LSB	1 LSB
C2 (Y1, c ₀)	193 LSB	193 LSB	193 LSB	193 LSB
C3 (Y2)	3896 LSB	3896 LSB	3896 LSB	3896 LSB
C4 (High clamp)	4088 LSB	4088 LSB	4088 LSB	4088 LSB
k	74.06 LSB/bar	13.225 LSB/bar	8.8167 LSB/bar	6.1717 LSB/bar
c ₀	193 LSB	193 LSB	193 LSB	193 LSB

Temperature measurement transfer function

The sensor measures the temperature in the ASIC (application-specific integrated circuit). According to the SENT specification SAE J2716 JAN 2010, the temperature characteristic is encoded as a 12-bit signal for Slow- and Fast-Channel:

Measured temperature

$$T_{\text{ist}} = \frac{T_{\text{OUT, code}}}{8 \times \text{round}} \text{ K} + 200\text{K}$$

Transfer function temperature

$$T_{\text{OUT, code}} = 8 \times \text{round} \left(\frac{T_{\text{ist}} - 200\text{K}}{\text{K}} \right)$$

Key

T_{ist} Temperature in Kelvin [K]

$T_{\text{OUT, code}}$ Digital 12 bit data value

Transfer characteristic of the temperature values [K] into 12-bit data values

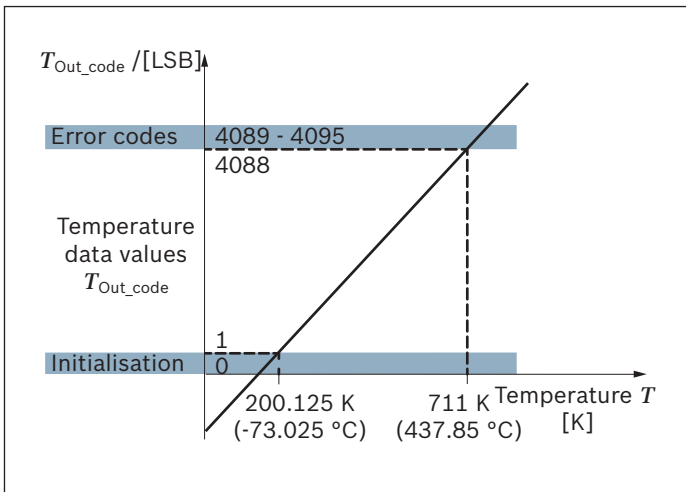

Maximum temperature until sending an error message:

160°C typical ± 20 Kelvin

Supply voltage measurement transfer function

According to the SENT specification SAE J2716 JAN 2010, the supply voltage is encoded as a 12-bit signal for Slow-Channel:

Measured supply voltage

$$U_{\text{ist}} = \frac{U_{\text{Val}}}{100 \times \text{round}} \text{ V}$$

Supply voltage

$$U_{\text{Val}} = 100 \times \text{round} \left(\frac{U_{\text{ist}}}{\text{V}} \right)$$

Key

U_{Val} Digital 12 bit data value

U_{ist} Voltage range in Volt [V]

Transmission characteristics of voltage supply [V] to 12-bit data values

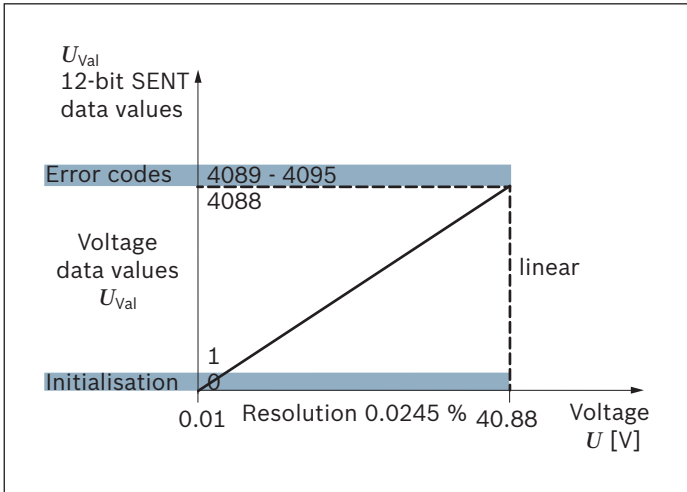

Threshold for the overvoltage error message:

5.65 ± 0.15 V

Threshold for the undervoltage error message:

4.35 ± 0.15 V

SENT-Slow-Channel Messages Order, meaning and values

In the Slow-Channel, this information is submitted in the order given as a continuous (repeating) sequence.

Message ID	Message order	Meaning	Hexadecimal value (decimal value)
0x01	1	Diagnostic Error Codes / Error and Status Codes	See table "Error Codes" ¹⁾
0x03	2	Channel 1 / 2 Sensor type Data values for the sensor types are defined in Table D.4 in SAE J2716 JAN 2010	0x7 (7)
0x04	3	Configuration Code Detailed specification of sensor type defined in Message 03 (Material number)	2)
0x05	4	Manufacturer Code Specific codes are assigned by the SAE SENT Task Force (B for Bosch)	0x42 (66)
0x06	5	SENT Standard Revision SENT SAE J2716 JAN 2010	0x3 (3)
0x23	6	Supplementary Data-Channel Bosch Codes: Internal Reference Temperature (PTAT/Diode) (TIC)	1)
0x1C	7	Supplementary Data-Channel Supply Voltage	1)
0x82	8	Bosch-specific Information	1)
0x01	9	Diagnostic Error Codes / Error and Status Codes	See table "Error Codes" ¹⁾
0x07	10	Fast-Channel 1 Characteristic X1 [Pa] Physical unit and encoding defined in application-specific appendices: Pressure transfer characteristic function (Channel 1)	0x0 (0)
0x08	11	Fast-Channel 1 Characteristic X2 [Pa] (Exponent + Mantisse = nominal measurement range)	2)
0x09	12	Fast-Channel 1 Characteristic Y1 [LSB]	193 LSB
0x0A	13	Fast-Channel 1 Characteristic Y2 [LSB]	3896 LSB
0x83	14	Configurable Message 1	0x1 (1)
0x84	15	Configurable Message 2	0x2 (2)
0x85	16	Configurable Message 3	0x3 (3)
0x01	17	Diagnostic Error Codes / Error and Status Codes	See table "Error Codes" ¹⁾
0x29	18	Sensor ID #1 12-bit for 48-Bit Serial Number	3)
0x2A	19	Sensor ID #2 12-bit for 48-Bit Serial Number	3)
0x2B	20	Sensor ID #3 12-bit for 48-Bit Serial Number	3)
0x2C	21	Sensor ID #4 12-bit for 48-Bit Serial Number	3)
0x80	22	IIR Lowpass Filter Setting	(0)
0x81	23	Supplier Info #2 Bosch Rexroth part number, coded (part1)	3)
0x90	24	Bosch Rexroth-specific Information	0x0 (0)
0x01	25	Diagnostic Error Codes / Error and Status Codes	See table "Error Codes" ¹⁾
0x91	26	Bosch Rexroth-specific Information	0x0 (0)
0x92	27	Bosch Rexroth-specific Information	0x0 (0)
0x93	28	Bosch Rexroth-specific Information	0x0 (0)
0x94	29	Bosch Rexroth-specific Information	0x0 (0)
0x95	30	Bosch Rexroth-specific Information	0x0 (0)
0x96	31	Bosch Rexroth-specific Information	0x0 (0)
0x97	32	Bosch Rexroth-specific Information	0x0 (0)

Default = 0

¹⁾ Variable values

²⁾ Depending on the pressure range and sensor type, this means the data changes for each material number.

³⁾ Changes for each sensor

Response after a reset and following initialization of the Sensor PR4 xxx xx SE /10

For certain faults (see "Fault diagnosis for sensor PR4 xxx xx SE /10") a reset is triggered in the sensor. After a reset and during the subsequent initialization of the sensor, the SENT message "Initialization 0" is sent exactly once as soon as the transmission is possible. As soon as pressure values and temperature values are available, they are sent.

There are two types of resets:

Hard-Resets: are executed immediately upon request.

Soft-Resets: are not executed until error conditions are still present after approx. 400 ms after power-on and the cause of the error could be reported under ID1 in the Slow-Channel.

The attempt to initiate a reset within 400 ms after power-on results in a continuous transmission of ID1 until the error condition is omitted or the reset is triggered after 400 ms.

Response after a reset of the Sensor PR4 xxx xx SE /10

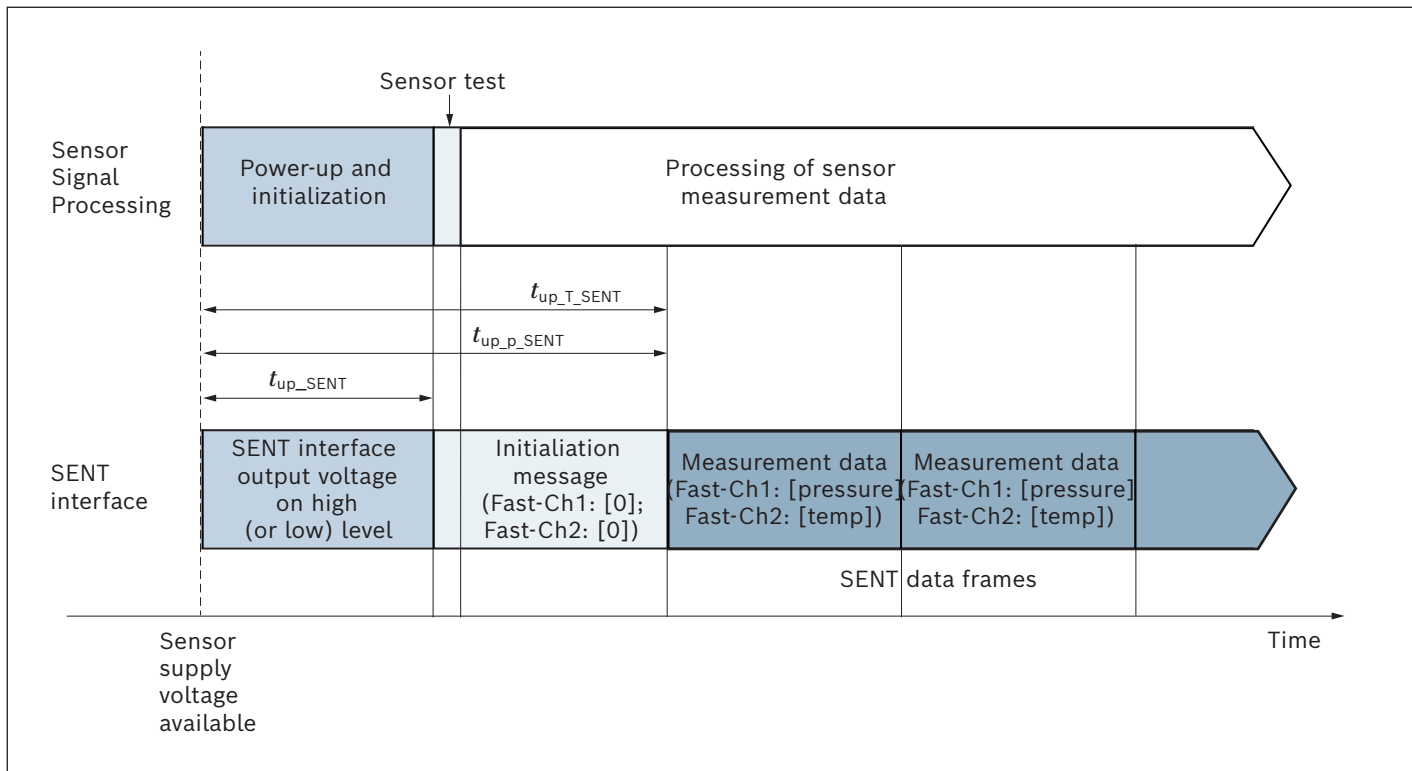

Values for the indicated times are available on request and are made available by Bosch Rexroth.

Behavior after undervoltage and overvoltage of the sensor PR4 xxx xx SE /10

The sensor PR4 xxx xx SE /10 can detect an undervoltage or overvoltage in the supply line. An undervoltage is detected when the supply voltage drops below a measured voltage threshold ($U_{mess\ under}$).

Overvoltage is detected when the supply voltage is above a voltage threshold ($U_{mess\ over}$).

The undervoltage / overvoltage detection is designed in such a way that continuous undervoltage / overvoltage (e.g. due to damaged cables or plug-in connections) and temporary undervoltage / overvoltage are detected.

Error diagnosis for Sensor PR4 xxx xx SE /10

For fault diagnosis, fault codes are transmitted in the Fast-Channel instead of data values (pressure or temperature), these are shown in the "Transmitted error codes on the Fast-Channel" table.

Transmitted error codes on the Fast-Channel

Transmission	Description PR4 xxx xx SE/10
4095	Used for the production stage (e.g. if errors occurred during the manufacturing process)
4094	Unused
4093	Unused
4092	Unused
4091	Error indication sensor element and front-end pressure measuring of sensor element and front-end error
4090	Error signal processing and signal perimeter
4089	Error message is sent due to reduced accuracy or reliability of the pressure signal
0	The initialization message is transmitted during the sensor initialization phase until valid measurement values are available (minimum one time after reset)

Note: Error indicator bits and serial message data (Message ID 01) carry additional information.

A further error detailing is described via information sent in the Slow-Channel. The assignment of the errors bet-

ween Fast-Channel and Slow-Channel as well as the associated priorities are shown in the "Error codes" table.

Error codes

Error description	Slow-Channel error codes [dec]	SENT Fast-Channel 1 error codes [dec]	SENT Fast-Channel 2 error codes [dec]	Channel 1 error bit 0 of status nibble	Channel 2 error bit 0 of status nibble	Internal reference temperature (PTAT/Diode) Supplementary Data-Channel #4.1 error codes	Sensor supply voltage Supplementary Data-Channel #3.1 error codes [dec]	Reset after Slow-Channel error message if set to 1 [bin]	Fast-Channel 1 measurement data priority (measured value is transmitted at FC rather than error)	Fast-Channel 2 measurement data priority (measured value is transmitted at FC rather than error)
Initialization (<i>p</i> and <i>T</i> not yet available)	0	0	0	0				0		
Factory use only (OTP bits not set)	0	4095	4095	1	1	4095	4095	0		
Error during initial or cycling HW check (RAM/ROM)	2070	4090	4090	1	1	4090	4090	1		
Error during initial CRC or cyclic trim data check	3	4090	4090	1	1	4090	4090	1		
Error during injection self test on power-up	2049	4091		1	0			1		
Internal timing error (buffer overflow)	2076	4089		1	0			0		
Sensor element error (FC1, pressure)	2064	4091		1	0			1		
Signal input ADC too high (FC1, pressure)	1	4091		1	0			1		
Signal input ADC too low (FC1, pressure)	2	4091		1	0			1		
Reference temperature input to high or low	2067	4091	4091	1	1	4091		0		
Failure of internal temperature sensor	2067	4091		1	0	4091		0		
Low voltage supply (threshold exceeded)	32	4089	4089	1	1	4089		0	1	1
High voltage supply (threshold exceeded)	33	4089	4089	1	1	4089		0	1	1
ASIC temperature high (threshold exceeded)	34	4089	4089	1	1		4089	0	1	1
Pressure above or below limit for error flag	2056			1	0			0		
Overflows or saturation in supply voltage path (measurement possibly unreliable or wrong)	2079			0	0		4089	0		
Overflows or saturation in signal paths (pressure, temperature, supply voltage)	2075			1	1			0		

Tolerances of the PR4 xxx xx 05/10 sensor

The tolerance of the pressure measurement is specified in % FS. FS = "full scale" refers to the nominal sensor pressure p_n usable range (4 V). The relative tolerance is pressure- and temperature-dependent and increases over the service life. In this connection, the service life comprises the entire specified service life respectively all specified tests. Stati-

stically, the tolerances for new parts are observed with ± 3 s per production lot. 100% sorted products may be delivered. After the service life, the tolerance range of the new parts may expand to the values highlighted in the diagram; here, the 3 s limit is in turn located maximally at the indicated tolerance limit.

Version 050 bar / 280 bar / 420 bar / 600 bar

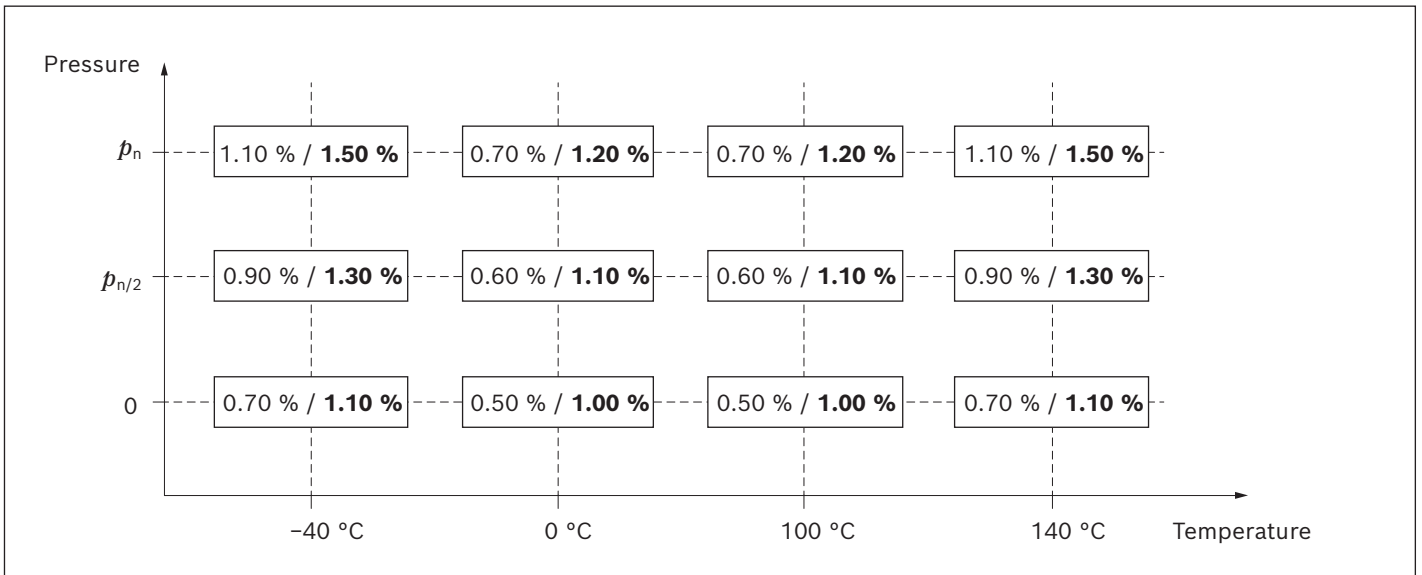

New condition unmounted / after life time

Version 100 bar / 400 bar

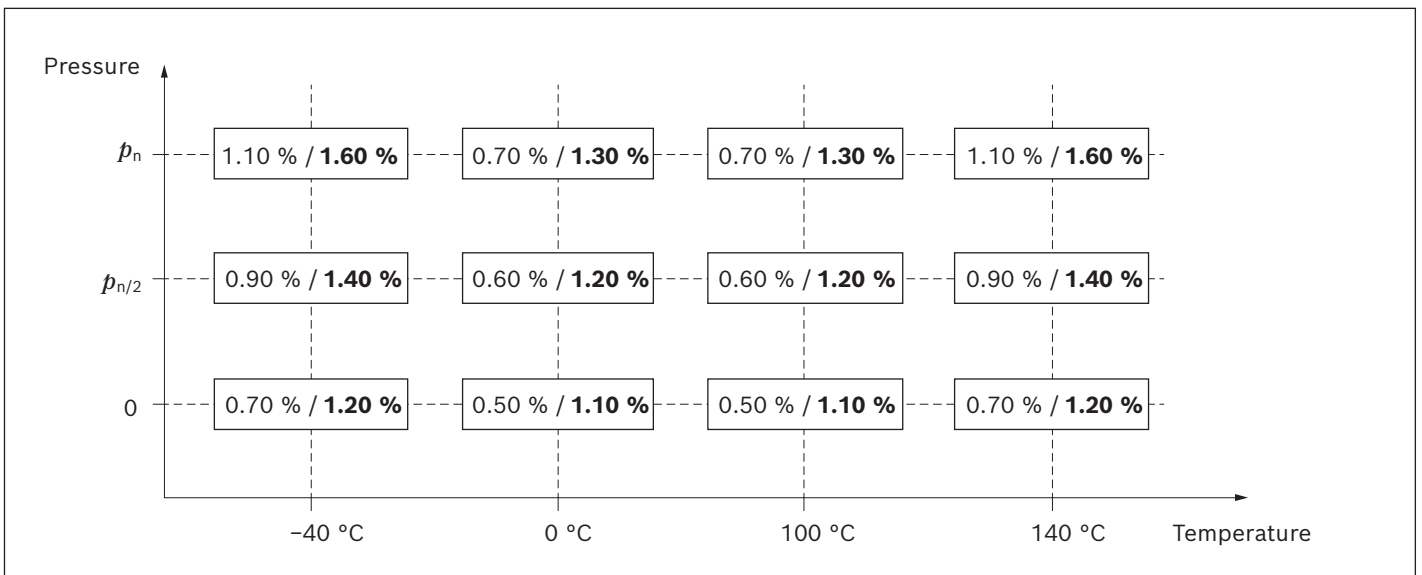

New condition unmounted / after life time

Tolerances of the PR4 xxx xx SE/10 sensor

The tolerance of the pressure measurement is specified in % FS. FS = "full scale" refers to the nominal sensor pressure p_n . The relative tolerance is pressure- and temperature-dependent and increases over the service life. Here, the service life comprises the entire specified service life. Statistically, the tolerances for new parts are observed

with ± 3 s per production lot. 100% sorted products may be delivered. After the service life, the tolerance range of the new parts may expand to the values highlighted in the diagram; here, the 3 s limit is in turn located maximally at the indicated tolerance limit.

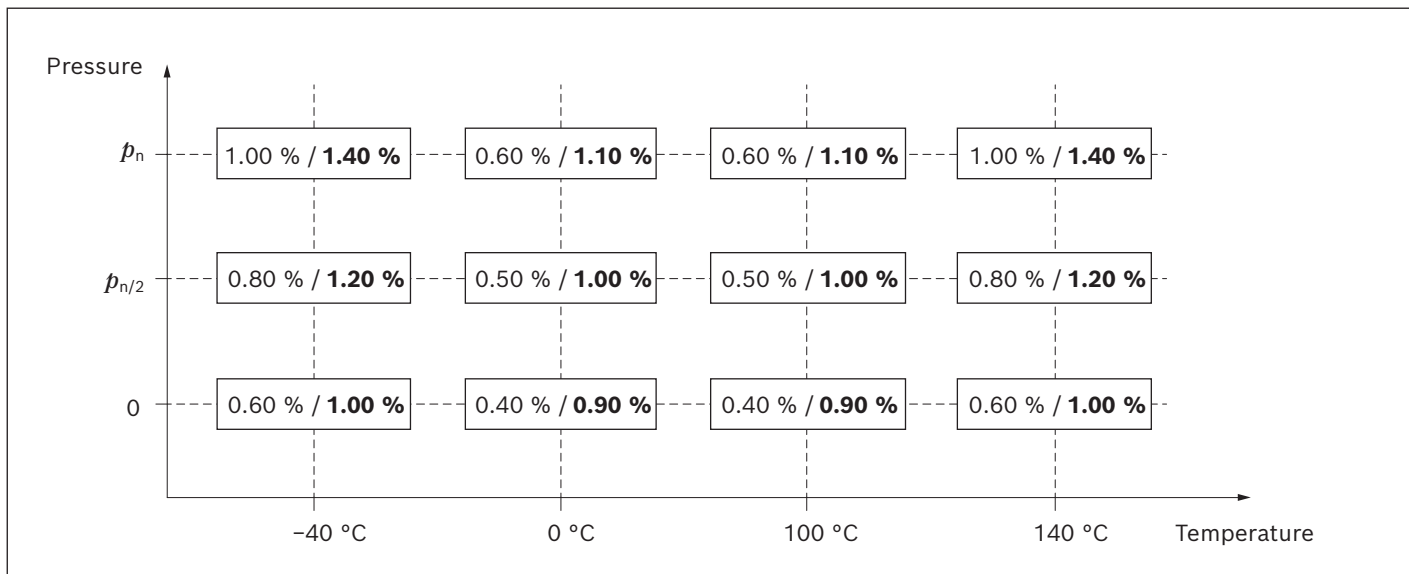

New condition unmounted / after service life

Tolerances of the PR4 xxx xx SE/10 temperature measurement

The relative tolerance is temperature-dependent. Statistically, the tolerances are observed with ± 3 s per production lot. 100% sorted products may be delivered.

▼ **The following tolerances apply to SENT 280 bar, SENT 420 bar and SENT 600 bar**

Temperature	Tolerance
< 25 °C	± 12 K over service life ± 10 K for new parts
25 ... 90 °C	± 7 K over service life ± 5 K for new parts
> 90 °C	± 12 K over service life ± 10 K for new parts

▼ **The following tolerances apply for all other pressures**

Temperature	Tolerance
-40 °C	± 12 K
30 °C	± 12 K
140 °C	± 12 K

Tolerances of the supply voltage measurement PR4 xxx xx SE/10

The high-pressure sensor transmits the level of the power supply with a tolerance of ± 150 mV.

Type codes

	01	02	03	04	05		06
BODAS	PR4					/	10

Type

01	Pressure sensor	PR4
----	-----------------	------------

Measuring range

02	0 ... 50 bar	050
	0 ... 100 bar	100
	0 ... 280 bar	280
	0 ... 400 bar	400
	0 ... 420 bar	420
	0 ... 600 bar	600

Mechanical connection

		050	100	280	400	420	600	
03	G 1/4 A in according to DIN EN ISO 1179-2	●	●	●	-	●	-	G
	M14 x 1.5 according to ISO 6149-2	-	-	-	●	-	●	M
	7/16-20 UNF according to SAE J 1926-1	-	-	●	-	●	●	U7
	9/16-18 UNF according to SAE J 1926-1	-	-	●	-	●	●	U9

Electrical connection

04	Bosch Compact	B
----	---------------	----------

Output signal

		050	100	280	400	420	600	
05	0.5 ... 4.5 V ratiometric (at 5±0 V supply)	●	●	●	●	●	●	05
	SENT according to SAE J2716 JAN 2010	●	-	●	-	●	●	SE

Series

06	10
----	-----------

● = Available - = Not available

Available variants¹⁾

Type	Material number Bulk pack (136 pieces)	Single pack
PR4 050 G B 05/10	R917C11189	R917A11189
PR4 050 G B SE/10	R917C11574	R917A11574
PR4 100 G B 05/10	R917C12392	R917A12392
PR4 280 G B 05/10	R917C05562	R917A05562
PR4 280 G B SE/10	R917C10997	R917A10997
PR4 280 U7 B 05/10	R917C12991	R917A12991
PR4 280 U7 B SE/10	R917C12997	R917A12997
PR4 280 U9 B 05/10	R917C12990	R917A12990
PR4 280 U9 B SE/10	R917C12994	R917A12994
PR4 400 M B 05/10	R917C12355	R917A12355
PR4 420 G B 05/10	R917C09842	R917A09842
PR4 420 G B SE/10	R917C11558	R917A11558
PR4 420 U7 B 05/10	R917C12842	R917A12842
PR4 420 U7 B SE/10	R917C12996	R917A12996
PR4 420 U9 B 05/10	R917C12843	R917A12843
PR4 420 U9 B SE/10	R917C12993	R917A12993
PR4 600 M B 05/10	R917C10105	R917A10105
PR4 600 M B SE/10	R917C11550	R917A11550
PR4 600 U7 B 05/10	R917C12844	R917A12844
PR4 600 U7 B SE/10	R917C12995	R917A12995
PR4 600 U9 B 05/10	R917C12845	R917A12845
PR4 600 U9 B SE/10	R917C12992	R917A12992

¹⁾ Further variants (incl. different electric connectors AK 3-pole code B, AK-Kostal 3-pole code A, Delphi Packard 3-pole code B, MLK 3-pole code B, trapezoidal 3-pole code B) upon request.

Technical data

Type PR4	050	100	280	400	420	600
Measuring range p_n	0 ... 50 bar	0 ... 100 bar	0 ... 280 bar	0 ... 400 bar	0 ... 420 bar	0 ... 600 bar
Maximum overpressure ¹⁾ p_{max}	100 bar	200 bar	400 bar	840 bar	560 bar	840 bar
Burst pressure (static) ²⁾³⁾ p_{Burst}	500 bar	2000 bar	2500 bar	4500 bar	3750 bar	4500 bar
Output signal	PR4 xxx xx 05/10: 0.5 ... 4.5 V, ratiometric (at 5 V supply) PR4 xxx xx SE/10: SENT according to SAE J2716 JAN 2010					
Supply voltage U_s	5±0.25 V					
Maximum supply voltage	18 V (max. 1 h)					
Short circuit signal output to GND or supply voltage	$U_{S, short} = 0 ... 18 V$, (max. 8 h) in case of simultaneous supply of U_s with $U_{S, short}$					
Sensor output impedance $R_{differential}$ at 0.1 $U_s < U_{out} < 0.9 U_s$	Typical: 5 Ω Maximum: 10 Ω					
Current consumption typical	12 mA (at 5 V supply voltage)					
Maximum current consumption	≤ 15 mA (at 5 V supply voltage)					
Reverse polarity protection of the supply voltage	yes ($U_s \leq 11 V$)					
Maximum current consumption in case of reverse polarity	260 mA					
Plug	Bosch Compact 1.1a, 3 pin, code 1					
Parts contacting with measuring medium	X5CrNiCuNb16-4					
Housing material	PBT-GF30/CrNi steel					
PR4 xxx xx 05 /10: Response time (10 % ... 90 %)	≤ 1 ms					
PR4 xxx xx SE /10: SENT data transfer	Time till the first SENT Data transmission min.: 1.8 ms, max.: 2.2 ms					
Overall accuracy	≤1.5%, refer to table "tolerance of the sensor PR4 xxx xx 05/10" or "PR4 xxx xx SE/10"					
Ambient temperature range	-40 ... +125 °C for UNF variants -40 ... +140 °C for others The sensor is designed for use in engine compartment (direct motor attachment) and the corresponding ambient temperatures with a typical temperature Distribution:					
	Temperature	Distribution				
	-40 °C	6%				
	23 °C	20%				
	85 °C	65%				
	135 °C	8%				
	140 °C	1%				
Storage temperature range	Maximum storage period from manufacturing date: 5 years at -30 ... +60 °C and 0 ... 80% relative humidity					
Transportation conditions	-40 ... +80 °C at 0% ...80% relative humidity, for the duration of max. 48h					
Service life	10000 operating hours or 15 years. Different values, depending on operational conditions on request					
Pressure cycles against service life	10 million cycles					

1) Maximum 15 minutes at p_{max}
 2) Maximum 15 minutes at p_{Berst}

3) The specific bursting pressure is valid for the device only. This value does not include the mechanical interface - the thread between the sensor and the hydraulic component.

Shock resistance	50 g (DIN EN 60068-2-27, 11 ms), 500 g (DIN EN 60068-2-27, 1 ms)		
Vibration resistance	Amplitude of the deflection	s = 0.25 mm in the range 70 ... 147 Hz	
	Amplitude of the acceleration	a = 210 m/s ² in the range 147 ... 1350 Hz	
		a = 175 m/s ² in the range 1350 ... 2000 Hz	
	Frequency change	0.5 octave/min	
Duration of excitation	100 h in each spatial direction with the same test specimen		
Drop test	Controlled drop from 1 m height onto concrete in accordance with ISO 16750-3 (2007-08-01). One drop event per axial direction. The component must then be fully functional or visually damaged		
Electromagnetic compatibility (EMC)	ISO 11452-2, -4, -5 as well as according to IEC 61000-4-2		
	BCI 100 mA	According to ISO 11452-4; 2 ... 400 MHz (closed loop; CBCI)	
	Antenna > 150 V/m	According to ISO 11452-2 from 200 MHz... 3.2 GHz	
Electrostatic discharge (ESD)	According to ISO 10605: 2008	Contact discharge	±8 kV (powered up and unpowered)
		Air discharge	±15 kV (powered up and unpowered)
Conformity according to	EMC directive 2014/30/EU with CE mark	Applied standards: EN ISO 14982:2009, ISO 13766-1, EN 12895	
	RoHS directive 2011/65/EU		
E1 type approval	UN ECE 10 - Rev. 4		
Electrical protection	Protection against reverse voltage, short circuit and undervoltage; protection against overvoltage in the defined supply voltage range		
Type of protection with installed mating connector	IP67 and IPX9K according to ISO 20653 (2006-08-15)		
Weight approx.	G 1/4 A: 48 g, M14 × 1.5 mm: 52 g		
Permissible hydraulic fluids	Mineral oil, HETG, HEPG, HEES, HFE, HFB, HFD, brake fluid (Other hydraulic fluids on request)		
Cable length	The maximum cable length with SENT has been defined according to SAE J2716 JAN 2010. Under certain conditions, this length may also be extended to up to 20 m. If cable lengths which exceed the applicable SENT standard SAE J2716 JAN 2010 are required, please contact the product management.		

Electrical connection

Pin Assignment

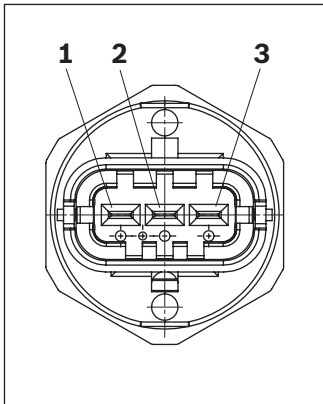

Pin	Connection	
1	Ground	GND
2	Output	
3	Supply voltage	U_s

Dimensions

Dimensions and labeling

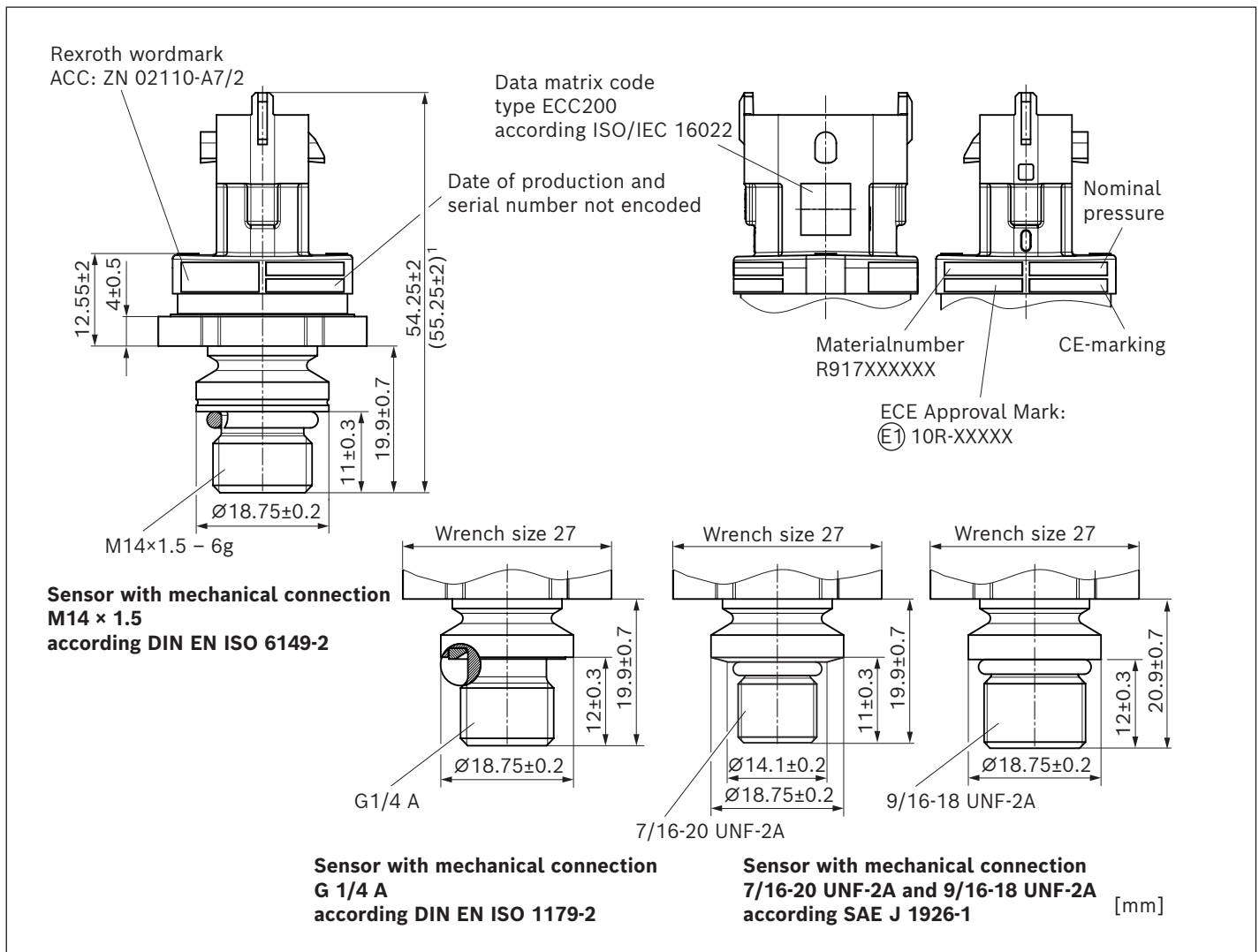

Data matrix code content

Content	Digits	Number
Material type: finished product	1	1
Material number R917XXXXXX	2 ... 11	10
Year of production	12 ... 13	2
Production day related to production year	14 ... 16	3
Serial number related to production day	17 ... 21	5
Number of production-line	22	1
Number of the manufacturing plant	23 ... 25	3
Internal Bosch Rexroth number	26 ... 30	5
Bosch Rexroth change index	31 ... 32	2
Bosch Rexroth drawing index	33 ... 35	3
Empty place for CD-free sensor	36	1

¹⁾ Clamp value valid for sensor version with mechanical connection 9/16-20 UNF

Mounting

Mounting process of sensor must be ensured by customer by adequate validation.

Bosch Rexroth recommends to wet the surface of thread and tightening plane of pressure sensor completely with Oil or Molykote WI5 prior to mounting.

To prevent accumulation of lubricant in the pressure port application of lubricant by spraying while pressure port

Installation position

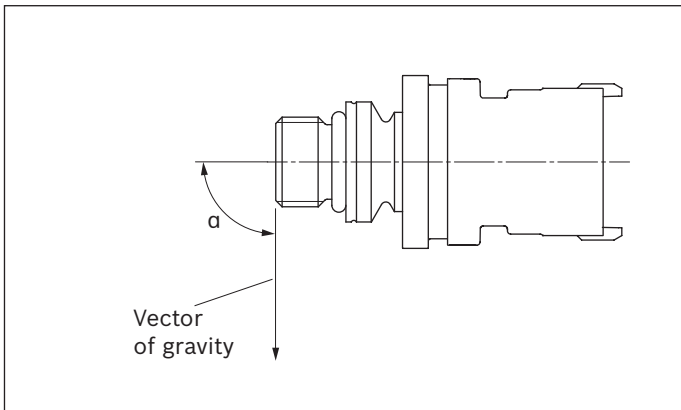

Mechanical connection

Before installing and removing the sensor, make certain that the system is not pressurized.

Tightening torque

Before mounting the PR4 pressure sensor, check the specified tightening torque of the hydraulic pump, motor or valve block.

If the torque for mounting the sensor in the respective hydraulic component is not specified use a torque of

facing downwards is recommended.

Recommended position:

$\alpha = \pm (0 \dots 90^\circ)$ to acceleration of gravity

Other mounting position, after acceptance of DC-MH and corresponding design of the system interface.

35 ±5 Nm for the sensors with the G 1/4 thread up to 420 bar and 45±5 Nm for the 600 bar sensors with the M14 × 1,5 mm thread.

The maximum tightening torque must not exceed 45 Nm for G 1/4 thread and 50 Nm for M14 × 1.5 thread.

Instruction for cable guide

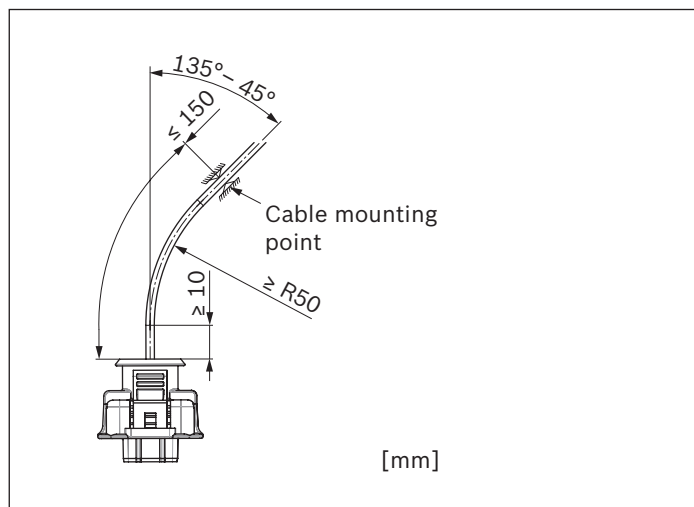

Assembly information

For assembly of connectors, please observe the assembly instructions for plug-in connections (Y 928 P00 222) and BDK 2.8 contacts (1 928 F00 025).

These assembly instructions are available on request from Bosch Rexroth.

Attention:

For assembly of the connector in the vehicle, the following must be observed:

- ▶ The wiring harness must be mechanically fastened within a distance of ≤ 150 mm from the connector.
- ▶ The wiring harness has to be secured in such a way that in-phase excitation with the sensor occurs.
- ▶ Use wiring harness connectors to protect the sensor against ingress of water.
- ▶ **The sensor has an air bleed bore and is leaky if the mating connector is not plugged in! During processing and/or assembly, you must therefore use suitable protection against the ingress of humidity.**

Required tooling¹⁾

Designation	Number	Ordering No.
Bosch crimping pliers for BDK 2.8 terminal 0.5, 0.75, 1.0 mm ² wire	1	1928498161
Bosch terminal dismantling tool for BDK 2.8 terminals	1	1928498167

Electrical connection

- ▶ The sensor may only be installed by qualified personnel (electrician).
- ▶ National and international specifications for installation of electrotechnical systems must be observed.
- ▶ Voltage supply according to SELV, PELV.
- ▶ The contacts in the connector of the sensor must not be touched during assembly.
- ▶ When connecting the mating connector, "hot plugging" must be prevented (= connection of the mating connector with live voltage).

¹⁾ The tools may be purchased from Bosch dealers or Bosch Service (www.bosch-service.com).

Information

Manufacturer confirmation of PR4 MTTFD_D-values

The component is not a safety component in the sense of the Machinery Directive 2006/42/EC and has not been developed according to ISO 13849-1:2015, and ISO 13849-2:2012.

Ambient temperature sensor [°C]	Self-heating [°C]	Temperature profile, operating time share [%]							
		1	2	3	4	5	6	7	8
-40	10	0	0	0	0	0	0	0	0
10	10	100	0	0	0	0	0	0	0
20	10	0	100	0	0	0	0	0	0
23	10	0	0	0	0	0	0	0	0
30	10	0	0	100	0	0	0	0	0
40	10	0	0	0	100	0	0	0	0
50	10	0	0	0	0	100	0	0	0
60	10	0	0	0	0	0	100	0	0
70	10	0	0	0	0	0	0	100	0
80	10	0	0	0	0	0	0	0	100
85	10	0	0	0	0	0	0	0	0
90	10	0	0	0	0	0	0	0	0
100	10	0	0	0	0	0	0	0	0
110	10	0	0	0	0	0	0	0	0
120	10	0	0	0	0	0	0	0	0
130	10	0	0	0	0	0	0	0	0
135	10	0	0	0	0	0	0	0	0
140	10	0	0	0	0	0	0	0	0
MTTF _D -value [years] with one operating time of	4 hrs/day	71601	51998	37273	26434	18552	12869	8806	5933
	8 hrs/day	44751	32499	23295	16521	11595	8043	5504	3708
	16 hrs/day	25597	18589	13325	9450	6632	4601	3148	2121
	24 hrs/day	17900	12999	9318	6608	4638	3217	2202	1483

Ambient temperature sensor [°C]	Self-heating [°C]	Temperature profile, operating time share [%]							
		9	10	11	12	13	14	15	
-40	10	0	0	0	0	0	0	0	6
10	10	0	0	0	0	0	0	0	0
20	10	0	0	0	0	0	0	0	0
23	10	0	0	0	0	0	0	0	20
30	10	0	0	0	0	0	0	0	0
40	10	0	0	0	0	0	0	0	0
50	10	0	0	0	0	0	0	0	0
60	10	0	0	0	0	0	0	0	0
70	10	0	0	0	0	0	0	0	0
80	10	0	0	0	0	0	0	0	0
85	10	0	0	0	0	0	0	0	65
90	10	100	0	0	0	0	0	0	0
100	10	0	100	0	0	0	0	0	0
110	10	0	0	100	0	0	0	0	0
120	10	0	0	0	100	0	0	0	0
130	10	0	0	0	0	100	0	0	0
135	10	0	0	0	0	0	0	0	8
140	10	0	0	0	0	0	0	100	1
MTTF _D -value [years] with one operating time of	4 hrs/day	3930	2559	1639	1034	644	397	3106	
	8 hrs/day	2456	1599	1025	647	403	248	1941	
	16 hrs/day	1405	915	586	370	230	142	1110	
	24 hrs/day	982	640	410	259	161	99	776	

The MTTFD_D-values were determined in accordance with ISO 13849-1:2015-12, Appendix D, Parts Count Method, and the specified temperature profiles below.

Assessment of safety principles

List of the safety principles that must be to take into account in the higher-level system.

Chapter	General safety principles	Comment	Technology	Area of use	Assessment
A.1.5	Adequate mounting	Observe manufacturer's application instructions when using screw locks. Overstraining can be avoided by using a suitable torque limitation method.	Mechanical	Components	Installation of the sensor protected for the intended use as described in the data sheet. The described loads must not be exceeded and the installation conditions must be observed by the customer.
C.1.5	Adequate mounting	For the application e.g. of screw locks, fittings, adhesives, clamping rings, observe the manufacturer's application notes. Overstraining can be avoided by applying a suitable torque limiting method.	Hydraulic	Components	Installation of the sensor protected for the intended use as described in the data sheet. The described loads must not be exceeded and the installation conditions must be observed by the customer.
D.1.6	Application of the principle of energy separation (GS-BGIA-M13: off-load current principle, spring, return spring)	A safe condition is achieved by separating all important equipment from the energy source, e.g. by using a normally closed (NC) contact for inputs (contact and position switches) and a normally open (NO) contact for relays [see also EN 292-2:1991 (ISO/TR 12100-2:1992), 3.7.1]. There can be exceptions in some cases, e.g. if a failure of the electrical supply represents an additional hazard. Time-delaying functions may be necessary to ensure that a safe condition of the system is achieved [see EN 60204-1:1997 (IEC 60204-1:1997), 9.2.2]	Electrical system	Components	The safe state is reached when the signal is in the error band. This is the case when the power supply is disconnected from the sensor.
A.1.7	Limitation of the range of environmental parameters	These parameters are e.g. temperature, humidity, impurities at the installation site. Observe the manufacturer's application notes.	Mechanical	Components	The ambient parameters specified in the data sheet must be observed.

Chapter	General safety principles	Comment	Technology	Area of use	Assessment
D.1.7	Suppression of voltage peaks	A mechanism for suppressing voltage peaks (RC element, diode, varistor) should be used parallel to the applied load but not parallel to the contacts. NOTE: The switch-off time is increased by a diode.	Electrical system	Components	The sensor is designed so that the peak voltages described in the data sheet do not damage the sensor or keep the sensor within the specification. The higher-level system must avoid voltage peaks.
D.1.9	Compatibility	Use of components that are suitable for the voltages and currents used (power supply unit).	Electrical system	Components	The sensor is designed so that the voltages and currents described in the data sheet are protected under the loads and installation situations described there. The higher-level system must comply with the specified voltages and currents.
C.1.13	Suitable temperature range	This must be taken into account throughout the system.	Hydraulic	Components	The sensor is designed so that the temperature loads described in the data sheet do not damage the sensor or keep the sensor within the specification. The specified temperature range must be observed.
A.1.14	Adequate protection to keep out fluids and dust	Observe the IP protection type [see EN 60529 (IEC 60529)].	Mechanical	Components	The sensor is protected against the intrusion of fluids or dust. The specified protection classes must be observed.

Chapter	Well-tried safety principles	Comment	Technology	Area of use	Assessment
D.3.4	Energy limitation	A capacitor is to be used to supply a limited amount of energy, e.g., when using a time cycle control.	Electrical system	Components	The supply voltage described in the data sheet must be observed.
D.3.5	Limitation of electrical parameters	Limiting of the voltage, current, energy or frequency to avoid an unsafe status, e.g. by torque limitation, offset/time-limited running and reduced speed.	Electrical system	Components	The supply voltage described in the data sheet must be observed.
D.3.6	Prevention of undefined conditions	Undefined conditions in the control system should be avoided. The control system must have a structural design that enables all expected control system operating conditions, e.g. output/outputs, to be predetermined.	Electrical system	Components	In the case of an error, the sensor signal goes into the error band (safe state) as described in the data sheet.
D.3.8	State switchover in event of failure	If possible, all mechanisms/circuits should transition to a safe state or be safe to operate.	Electrical system	Components	In the case of an error, the sensor signal goes into the error band (safe state) as described in the data sheet.
D.3.9	Directed failure	If it is possible to implement, components or systems should be used whose types of failure are known in advance [see EN 292-2:1991 (ISO/TR 12100-2:1992), 3.7.4].	Electrical system	Components	In the case of an error, the sensor signal goes into the error band (safe state) as described in the data sheet.

Accessories

Mating connector

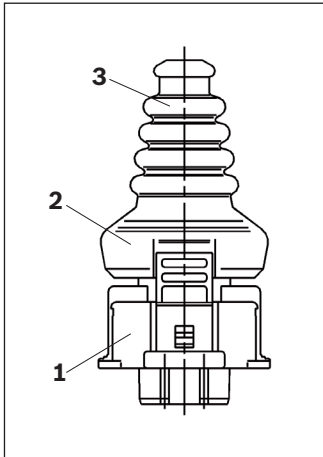

Position	Designation
1	Compact 1.1a / Plug 3P / Cod. 1
2	End clip
3	Cap straight

Mating connector¹⁾

The suitable connector set is available under Rexroth material number R917009890 for manual assembly of wiring harness connectors for laboratory or small series requirements with the following contents:

Mating connector R917009890

Designation	Number	Ordering No.
Bosch Compact 1.1a connector	1	1928403966
BDK 2.8 Terminal Gold for 18 ... 20 AWG, 0.5 ... 1.0 mm ²	3	1928498054
Bosch compact cap straight	1	1928300527
BDK 2.8 / Single seal / Ø1.2 ... 2.1 mm / blue for insulation diameter 1.2 ... 2.1 mm	3	1928300599
End clip	1	1928403423

Further variants of the mating connector are available from Robert Bosch GmbH as well as via distribution.

See also the list in the drawing:

A 928 000 453 - Offer drawing compact plug 1.1²⁾

¹⁾ The mating connector is not included in the scope of delivery. This can be supplied by Bosch Rexroth on request.

Protective cap (For PR4 with Bosch compact connector)

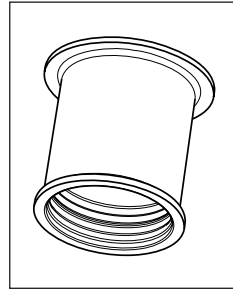

The protective cap is used to protect against moisture or fluids which can enter the sensor via the connector as long as the cable wiring harness connector / mating connector is not plugged in.

In addition, it can also be used as transport protection for the connector.

The protective cap can be ordered at Bosch Rexroth Elchingen.

Designation	Material number
Protective cap	R913078779

²⁾ Drawings and further information about Bosch connectors and tools can be found on the internet: www.bosch-connectors.com

Safety Instructions

General instructions

- ▶ Request a binding installation drawing before completing your design.
- ▶ The proposed circuits do not imply any technical liability for the system or the machine on the part of Bosch Rexroth.
- ▶ Opening the sensor or carrying out modifications to or repairs on the sensor is prohibited. Modifications to or repairs on the wiring can lead to dangerous malfunctions.
- ▶ Pressure gages may only be installed by trained personnel authorized by the system operator.
- ▶ Ports may only be opened in a depressurized state.
- ▶ The sensor may only be assembled/disassembled in a depressurized and de-energized state.
- ▶ When reassembling a sensor, the O-ring must be replaced.
- ▶ In order to prevent damage to the sensor and maintain its impeccable function, a professional air bleed of the hydraulic system is required.
- ▶ Only trained and experienced specialists who are adequately familiar with both the components used and the complete system should implement system developments or install and commission electronic systems for controlling hydraulic drives.
- ▶ When commissioning the sensor, the machine may pose unforeseen dangers. Before commissioning the system, you must therefore ensure that the vehicle and the hydraulic system are in a safe condition.
- ▶ Make sure that nobody is in the machine's danger zone.
- ▶ Do not use defective components or components which are not in a proper working order. If the sensor fails or demonstrates a faulty operation, it must be replaced.
- ▶ Residual measurement media in dismantled pressure gages may cause hazards to people, the environment and equipment. Adequate precautions must be taken.
- ▶ Despite the greatest care being taken when compiling this document, it is not possible to consider all feasible applications. If notices for your specific application are missing, please contact Bosch Rexroth.

Notices on the installation location and position

- ▶ Do not install the sensor close to parts that generate considerable heat (e.g., exhaust).
- ▶ The connection lines are to be routed with sufficient distance from hot or moving vehicle parts.
- ▶ A sufficient distance to radio systems must be maintained.
- ▶ Before electric welding and painting operations, the sensor must be disconnected from the power supply and the sensor connector must be removed.
- ▶ Painting the sensor with electrostatic charge is not permitted (danger: ESD damage).
- ▶ Cables/wires must be equipped with an individual seal to prevent water from entering the sensor
- ▶ With a suitable installation in the vehicle, it is to be ensured that there is no water accumulation in the diaphragm (danger: measuring bridge detuning or diaphragm fracture in case of frost).

Notices on transport and storage

- ▶ Please examine the sensor for any damage which may have occurred during transport. If there are obvious signs of damage, please inform the transport company and Bosch Rexroth immediately.
- ▶ If the sensor is dropped, it is not permissible to use it any longer, as invisible damage could have a negative impact on reliability.
- ▶ Store the sensor in a dry and dust-free place. Ensure that any contamination with fluid or solid media in the area of the connector or on the thread can be excluded.
- ▶ Atmospheres containing sulfur are to be avoided in silver-plated connector pinning. For this application, we recommend using gold-plated contacts.
- ▶ The storage conditions described in the chapter "Technical data" do not lead to any change in the characteristics and the function of the high-pressure sensor.
- ▶ Upon exceedance of the maximum storage duration, the sensors must be returned to Bosch Rexroth AG for examination.

Notices on wiring and circuitry

- ▶ Use twisted lines for the connection of the sensor.
- ▶ To minimize voltage drop in the line, the lines used must be as short as possible and, if applicable, have a larger cross section between the sensor and the electronic control unit.
- ▶ We recommend using twisted and shielded lines as well as connecting one side of the shield to the vehicle ground or the housing ground of the electronics.
- ▶ The sensor mating connector must only be plugged and unplugged when it is in a de-energized state.
- ▶ The sensor lines are sensitive to spurious interference. For this reason, the following measures should be taken when operating the sensor:
 - Sensor lines should be attached as far away as possible from large electric machines.
 - If the signal requirements are satisfied, it is possible to extend the sensor cable.
- ▶ Lines from the sensor to the electronics must not be routed close to other power-conducting lines in the device or vehicle.
- ▶ The wiring harness should be fixated mechanically in the area in which the sensor is installed (distance < 150 mm). The wiring harness should be secured so that in-phase excitation with the sensor occurs (e.g. at the sensor mounting point).
- ▶ If possible, lines should be routed in the vehicle interior. If the lines are routed outside of the vehicle, their secure mounting is to be ensured.
- ▶ Lines must not be kinked or twisted, must not rub against edges and must not be routed through sharp-edged ducts without protection.
- ▶ The Bosch Rexroth warranty only covers the function of the plug-in system in combination with wiring harness connector system parts according to this data sheet.
- ▶ Only use appropriate tools for crimping and installing the mating connector.
- ▶ Bending of the cable (deviation from the straight line) between cable outlet at the sensor and first assembly point, 20 ... 90°.
- ▶ Permissible bending radius of the cable until the first cable diameter: $R \geq 50 \text{ mm}$.

Intended use

- ▶ The sensor is designed for use in mobile working machines provided that no limitations/restrictions are made to certain application areas in this data sheet.
- ▶ Before installation, commissioning and operation, you must always ensure that the correct pressure gage has been selected with regard to measurement range, version and specific measurement conditions, and that the gage is suitable for wetted material (corrosion). National safety regulations must also be observed.
- ▶ Generally, the sensor must be operated within the operating ranges specified and approved in this data sheet, particularly with regard to voltage, temperature, vibration, shock and other described environmental influences.
- ▶ If necessary, a throttle in the hydraulic system which limits possible pressure peaks and pulses must be installed. Please also observe any specific operating conditions which could cause cavitation, for example. Make sure to avoid any stress exceeding the specified values. Cavitation must be prevented in any operation or standby mode.
- ▶ Its use outside of these specified and approved boundary conditions may result in danger to life and/or cause damage to components which could result in sequential damage to the mobile working machine.
- ▶ Severe personal injury and/or damage to property may occur in case of non-compliance with the corresponding specifications.

Improper use

- ▶ Any use of the sensor other than that described in the chapter "Intended use" is considered to be improper use.
- ▶ Its use in explosive areas is not permitted.

Use in safety-related functions

- ▶ The customer is responsible for performing a risk analysis of the mobile working machine and determining the possible safety-related functions.
- ▶ In safety-related applications, the customer is responsible for taking proper measures to ensure safety (sensor redundancy, plausibility check, etc.).

Disposal

- ▶ The sensor and its packaging must be disposed of according to the national environmental regulations of the country in which the sensor is used.

Further information

- ▶ Further information about the sensor can be found at www.boschrexroth.com/mobile-electronics.

- ▶ Damage resulting from its improper use and/or from an unauthorized intervention which is not specified in this data sheet voids all warranty and liability claims against the manufacturer.

- ▶ Product data that is required for the safety assessment of the machine is included in this data sheet.

Bosch Rexroth AG

Robert-Bosch-Straße 2
71701 Schwieberdingen
Germany
Service Tel. +49 9352 40 50 60
info.bodas@boschrexroth.de
www.boschrexroth.com

© Bosch Rexroth AG 2021. All rights reserved, also regarding any disposal, exploitation, reproduction, editing, distribution, as well as in the event of applications for industrial property rights. The data specified within only serves to describe the product. No statements concerning a certain condition or suitability for a certain application can be derived from our information. The information given does not release the user from the obligation of own judgment and verification. It must be remembered that our products are subject to a natural process of wear and aging.